

	Aislamiento eléctrico Electrical isolation	CIII
	Índice de estanqueidad Sealing rating	IP65
W_T	Potencia Power	15W

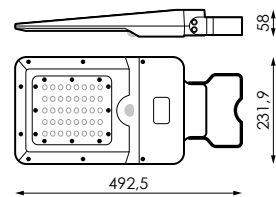

15W

PRECAUCIONES:

- Desconecte la corriente antes de instalar el producto.
- Mantenga el producto fuera del alcance de los niños.
- No sumerja este producto en agua ni lo manipule con las manos mojadas.
- No usar guantes ni cualquier material plástico.
- No golpee el producto.
- No instale el producto donde haya fuentes de calor o concentraciones de humedad.
- No manipule el producto mientras se encuentre en funcionamiento y déjelo enfriar antes de tocarlo con las manos.
- Mantenga una distancia mínima de 1m con la superficie u objeto a iluminar.
- La pantalla no debe ser cubierta por material aislante térmico en ningún caso.
- Si el producto se encuentra dañado sustitúyalo inmediatamente por uno nuevo.
- Manipular la luminaria sujetando el cuerpo, nunca presionando el difusor ya que podría hundirse y dañar la fuente de luz (LED).
- Esta luminaria contiene componentes sensibles a la electricidad estática y una descarga sobre ella podría destruir o dañar sus componentes.
- Lámpara no reemplazable.

AVISO

- Antes de comenzar la instalación de éste producto, por favor, lea atentamente las instrucciones y guárdelas en un sitio seguro.
- La instalación debe realizarla personal cualificado.
- La inadecuada manipulación de los componentes o de la propia luminaria podría dañar el correcto funcionamiento de este producto, quedando anulada la garantía del fabricante.
- La garantía cubre única y exclusivamente el producto suministrado.
- Las averías ocasionadas por instalaciones fuera de lo que indica el rebt 2002 eximen de la vigencia de la garantía en los productos dañados.
- Es de obligado cumplimiento en instalaciones interiores la aplicación del artículo 16, punto 3 del rebt 2002.



ATENCIÓN!!! RESPETAR LAS PRECAUCIONES DE MANIPULACIÓN DE LOS COMPONENTES SENSIBLES A DESCARGAS ELECTROSTÁTICAS (LED).

PRECAUTIONS:

- Disconnect current before installing device.
- Keep product out of the reach of children.
- Do not immerse this device in water or handle it with wet hands.
- Do not use gloves or any plastic material.
- Be careful not to bang the device.
- Do not install the product in the presence of heat sources or high concentration of moisture.
- Do not handle the product whilst it is in use and allow it to cool down before hand contact.
- Maintain a minimum distance of 1m between the device and the nearer surface or object.
- Under no circumstances should the screen be covered with thermal insulation material.
- If the device is faulty, replace immediately with a new one.
- Handle the light fixture by holding the body, never the diffuser, as it may collapse and damage the light source (LED).
- A discharge on this light fixture may destroy or damage its electrostatic sensitive components.
- Non-replaceable lamp.

WARNING

- Before installing this product, please read the instructions carefully and store them in a safe place.
- The installation should be carried out by trained staff.
- Incorrect handling of the parts or the light fixture itself may impair the proper performance of this product. In this case, the manufacturer guarantee shall be deemed void.
- The manufacturer guarantee shall be deemed void: if the installation is not performed in accordance with the spanish low voltage electrotechnical regulation 2002 (rebt 2002).
- The application of ibc bt09-4 of rebt (installation of line and light fixture surge protectors) is essential for industrial and public lighting installations. The guarantee does not cover against damages caused by surges in light fixtures without surge protectors installed.

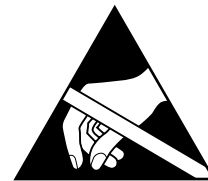

ATTENTION!!! OBSERVE PRECAUTIONS FOR HANDLING ELECTROSTATIC SENSITIVE DEVICES.

FIG.1

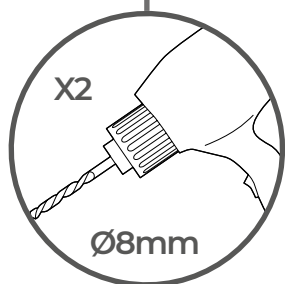
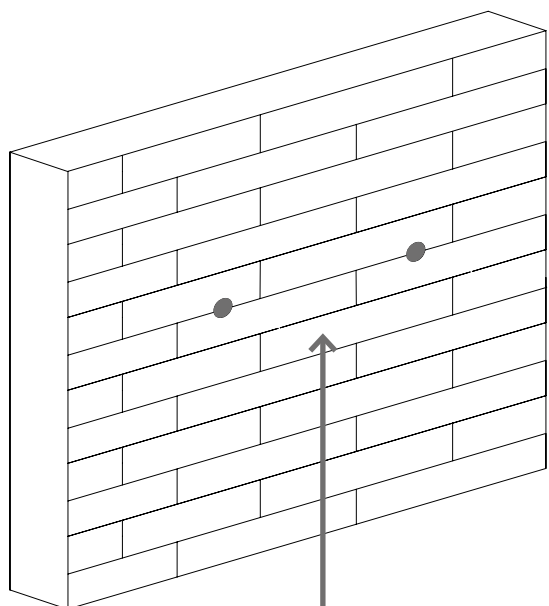

FIG.2

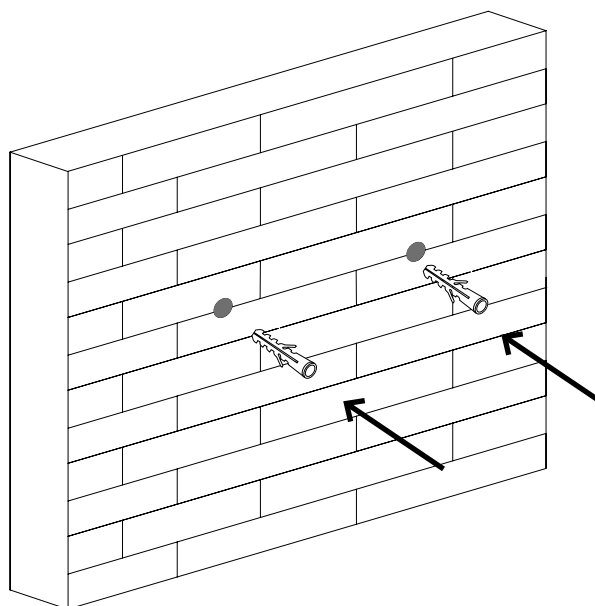
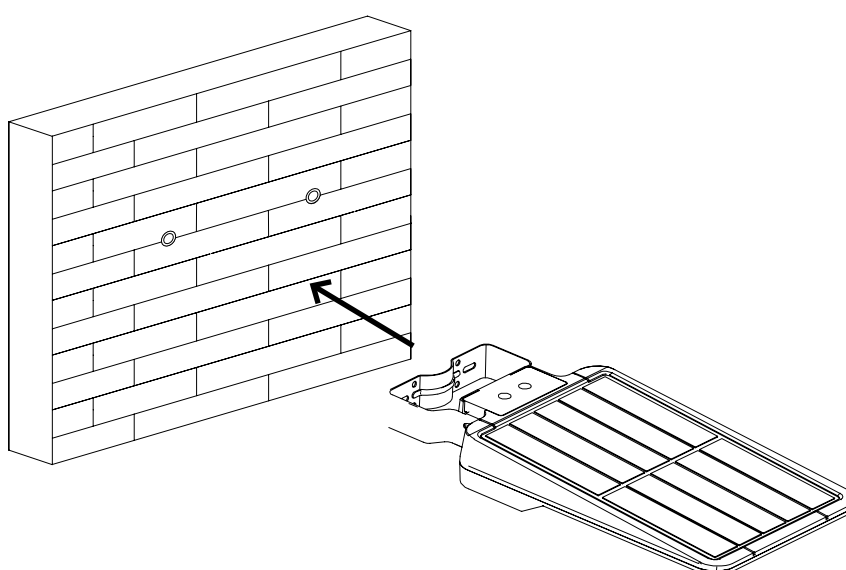

FIG.3



AVISO / WARNING

Altura de instalación 3-5m
Installation height 3-5m

MONTAJE EN COLUMNA / POLE MOUNTING

FIG.1

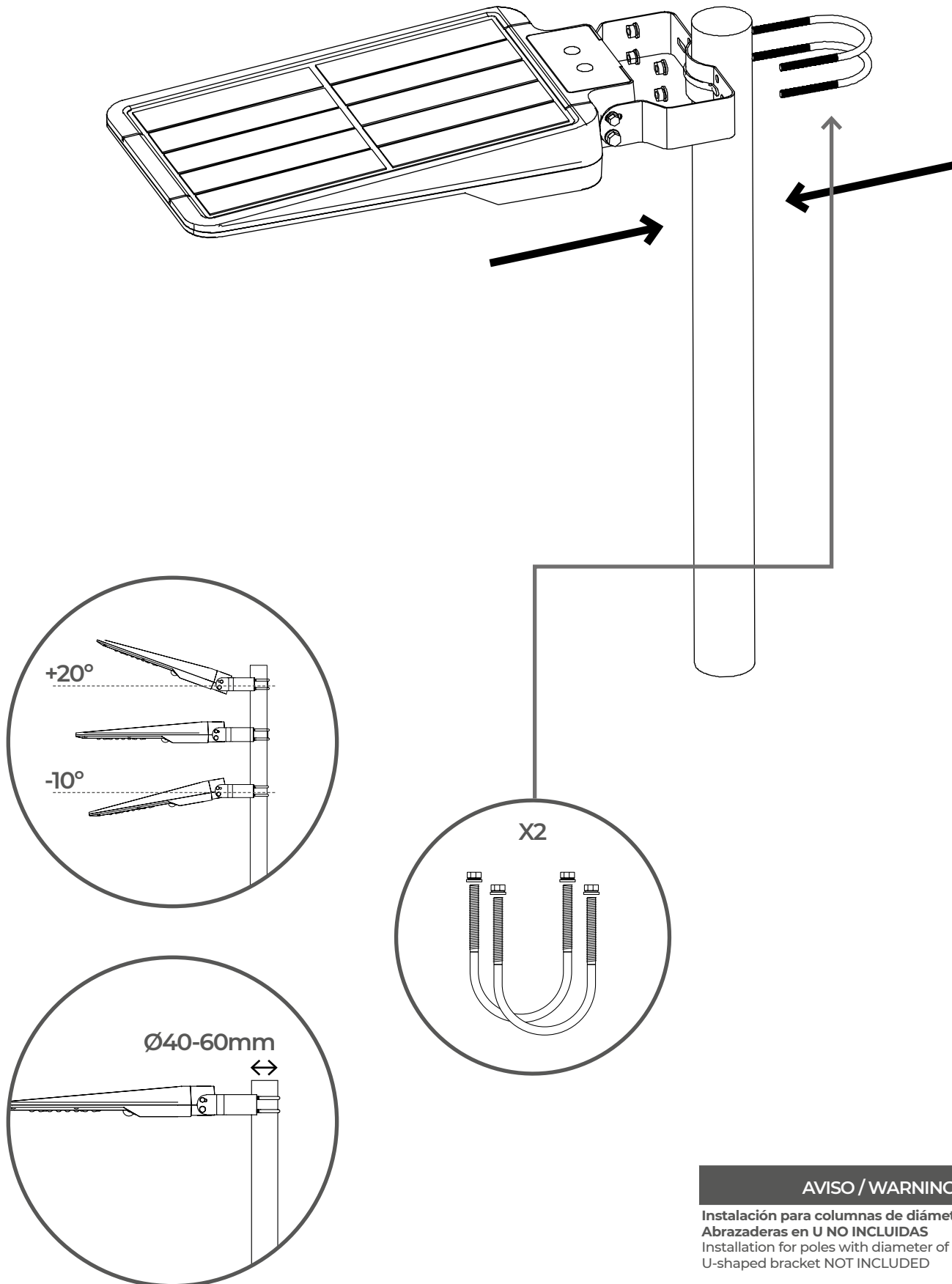

AVISO / WARNING

Instalación para columnas de diámetro $\text{Ø}40\text{-}60\text{mm}$
Abrazaderas en U NO INCLUIDAS
Installation for poles with diameter of $\text{Ø}40\text{-}60\text{mm}$
U-shaped bracket NOT INCLUDED

MONTAJE EN BÁCULO / CURVED POLE MOUNTING

FIG. 1

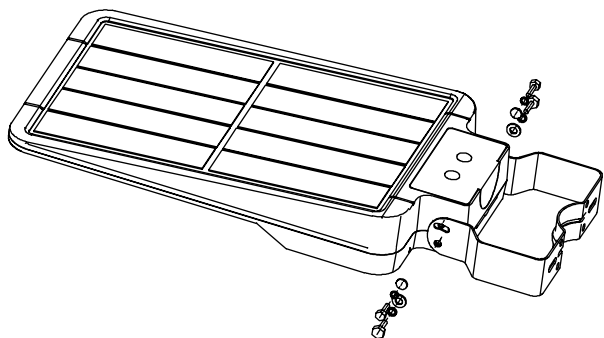

FIG. 2

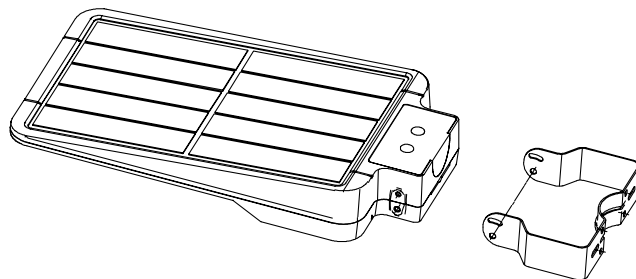

FIG. 3

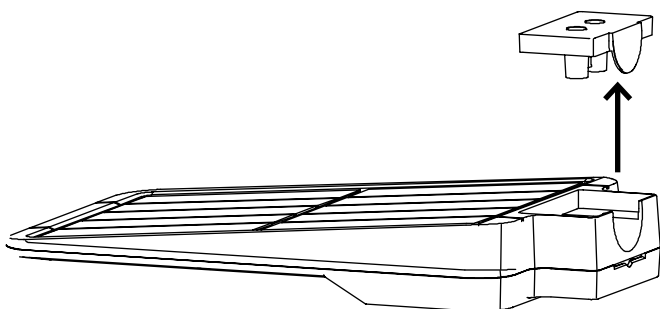

FIG. 4

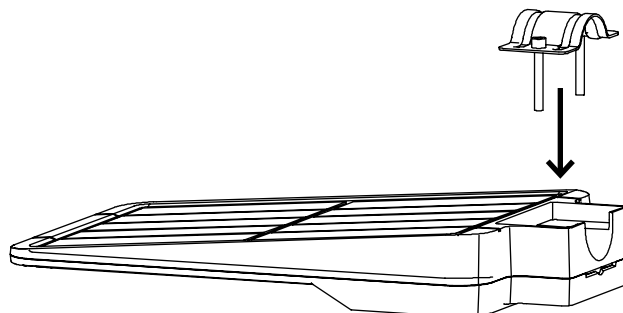
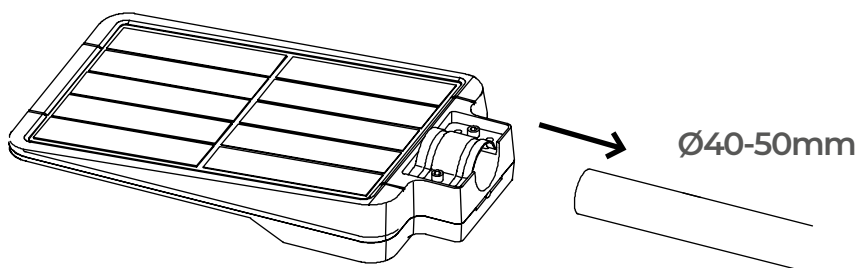

FIG. 5



AVISO / WARNING

Instalación para báculos de diámetro $\text{Ø}40\text{-}50\text{mm}$
Installation for poles with diameter of $\text{Ø}40\text{-}50\text{mm}$

MODOS DE ILUMINACIÓN / WORKING MODES

Esta luminaria tiene un modo de trabajo de ajuste automático. Solo necesita presionar el botón una vez, funcionará de forma permanente.

This luminaire is with auto-adjusting working mode, you only need to press the button once, it will work permanently.

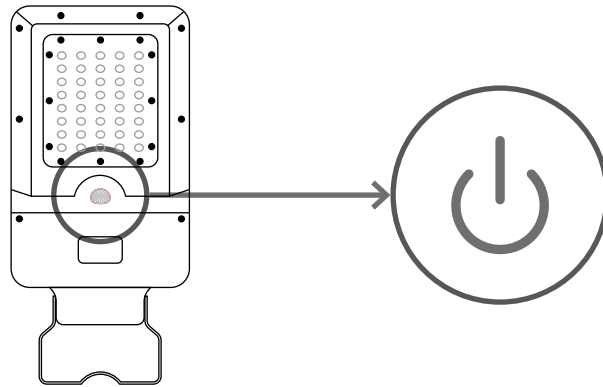

Primeras 5 horas

La luminaria se enciende automáticamente a su máximo nivel (100%) cuando se detecta movimiento, dentro de un rango de hasta 8m. Después de 20 segundos sin movimiento el nivel se atenúa.

First 5h lighting

Automatically turns on to full brightness when motion is detected in the range of 8m and then turns to weak brightness in 20 seconds of no motion.

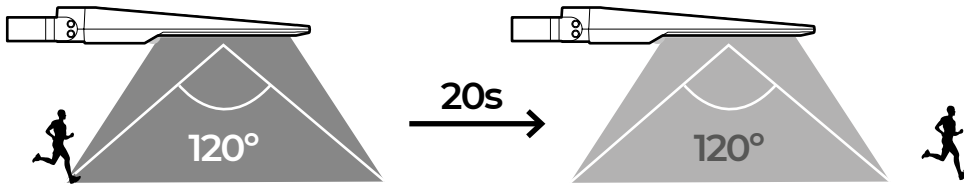

Después de 5h / Nivel de batería inferior a 30%

La luminaria se enciende automáticamente a su máximo nivel (100%) cuando se detecta movimiento, dentro de un rango de hasta 8m. Después de 20 segundos sin movimiento el nivel se atenúa. Después de 5 minutos sin movimiento la luminaria se apaga.

After 5Hrs lighting / Battery capacity below 30%:

Automatically turns on to full brightness when motion is detected in the range of 8m. Then turns to weak brightness in 20 seconds of no motion. After of 5 minutes without motion luminaire turns off.

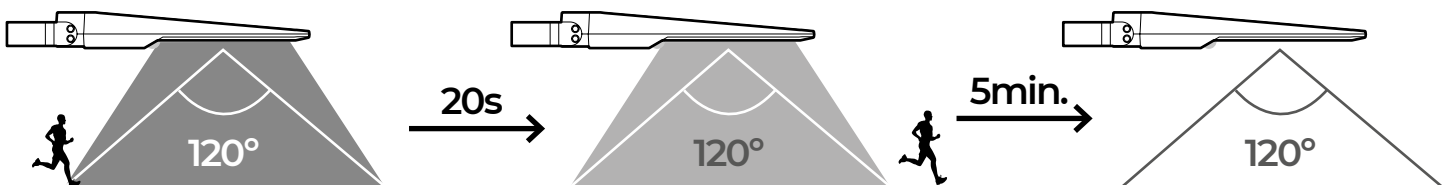



prilux.es

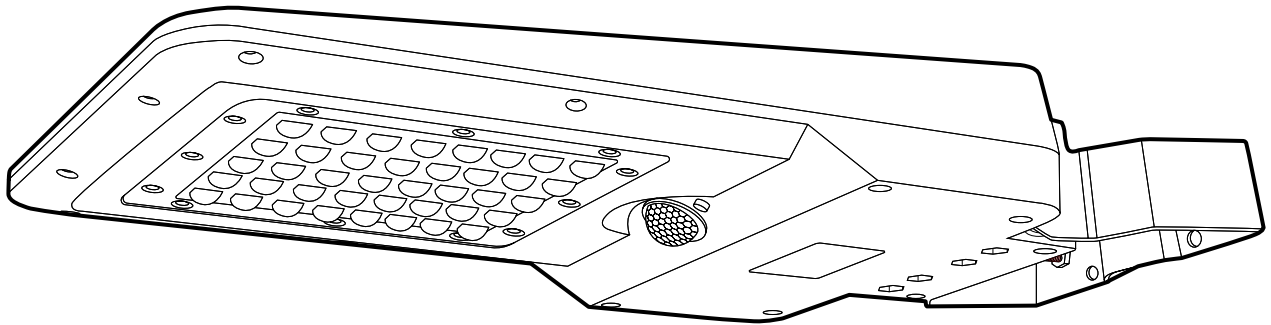
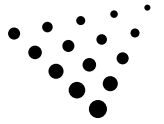

PRILUX 



	Isolation électrique Isolamento elétrico	CIII
	Indice d'étanchéité Índice de estanqueidade	IP65
	Puissance Potência	15W

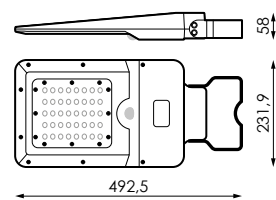

15W

PRÉCAUTIONS:

- Couper l'alimentation avant d'installer le produit.
- Tenir le produit hors de portée des enfants.
- Ne pas immerger ce produit dans l'eau ou le manipuler avec les mains mouillées.
- Ne pas utiliser de gants, ni de matériau plastique.
- Ne pas cogner le produit.
- Ne pas installer le produit dans un endroit où il y a des sources de chaleur ou des concentrations d'humidité.
- Ne pas manipuler le produit pendant son fonctionnement et le laisser refroidir avant de le toucher avec vos mains.
- Garder une distance minimale d'1m avec la surface ou l'objet à éclairer.
- Le produit ne doit en aucun cas être recouvert d'un matériau d'isolation thermique.
- Si le produit est endommagé, le remplacer immédiatement par un nouveau.
- Manipuler le luminaire en tenant le corps, ne jamais appuyer sur le diffuseur car il pourrait s'enfoncer et endommager la source de lumière (LED).
- Ce produit contient des composants sensibles à l'électricité statique et une décharge électrique pourrait détruire ou endommager les composants.
- LED non remplaçable.

AVERTISSEMENT

- Avant de commencer l'installation de ce produit, veuillez lire attentivement les instructions et les conserver dans un endroit sûr.
- L'installation doit être effectuée par du personnel qualifié.
- Une manipulation inappropriée des composants ou du luminaire pourrait nuire au bon fonctionnement de ce produit, annulant ainsi la garantie du fabricant.
- La garantie du fabricant est annulée : si l'installation n'est pas effectuée conformément au règlement électrotechnique pour basse tension espagnol (rebt 2002).

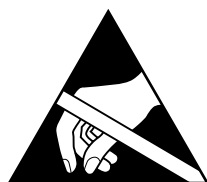

RESPECTER LES PRÉCAUTIONS DE MANIPULATION DES COMPOSANTS SENSIBLES AUX DÉCHARGES ÉLECTROSTATIQUES (LED).

PRECAUÇÕES:

- Desligar a corrente antes de instalar o produto.
- Manter o produto fora do alcance das crianças.
- Não mergulhar este produto em água, nem o manipular com as mãos molhadas.
- Não usar luvas nem qualquer material plástico.
- Não golpear o produto.
- Não instalar o produto onde houver fontes de calor ou concentrações de humidade.
- Não manipular o produto enquanto este se encontrar em funcionamento e deixar arrefecer antes de tocar com as mãos.
- Manter uma distância mínima de 1m em relação à superfície ou objeto a iluminar.
- O produto nunca deverá ser coberto por material isolador térmico.
- Se o produto se encontrar danificado, substituir imediatamente por um novo.
- Manusear a luminária segurando no corpo, sem nunca pressionar o difusor, pois poderia ceder e danificar a fonte de luz (LED).
- Este produto contém componentes sensíveis à eletricidade estática e uma descarga sobre o mesmo poderia destruir ou danificar os seus componentes.
- LED não substituível.

AVISO

- Antes de começar a instalação deste produto, por favor leia atentamente as instruções e guarde-as num lugar seguro.
- A instalação deve ser realizada por pessoal qualificado.
- A manipulação imprópria dos componentes ou da própria luminária poderá prejudicar o funcionamento correto deste produto, ficando anulada a garantia do fabricante.
- Fica anulada a garantia do fabricante: se a instalação não se realizar conforme indicado no rebt 2002.

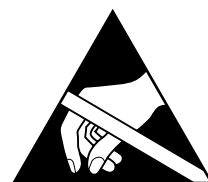

RESPEITAR AS PRECAUÇÕES DE MANIPULAÇÃO DOS COMPONENTES SENSÍVEIS A DESCARGAS ELETROSTÁTICAS (LED).

MONTAGE SURFACE / MONTAGEM SUPERFÍCIE

FIG.1

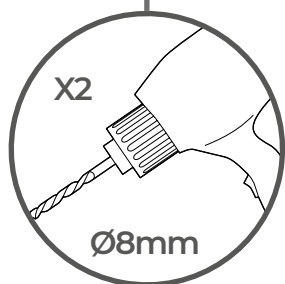
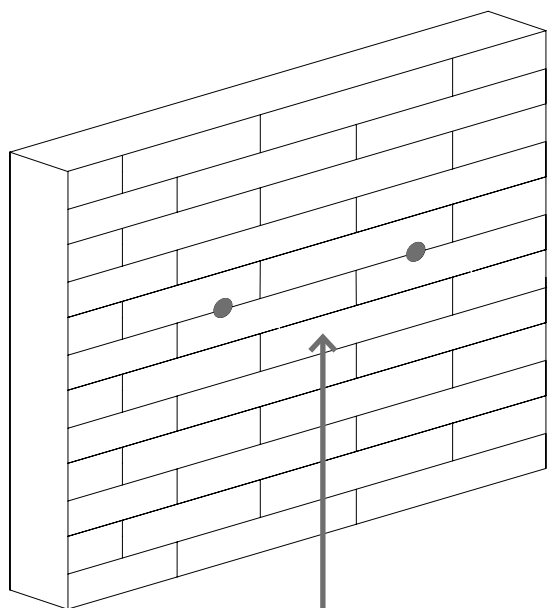

FIG.2

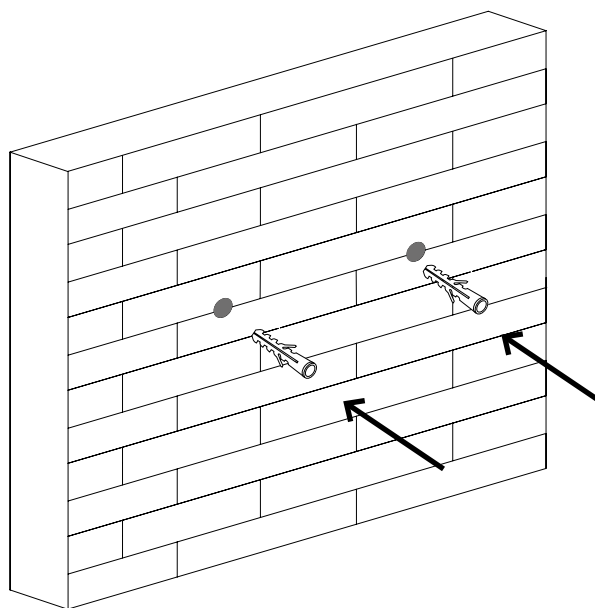
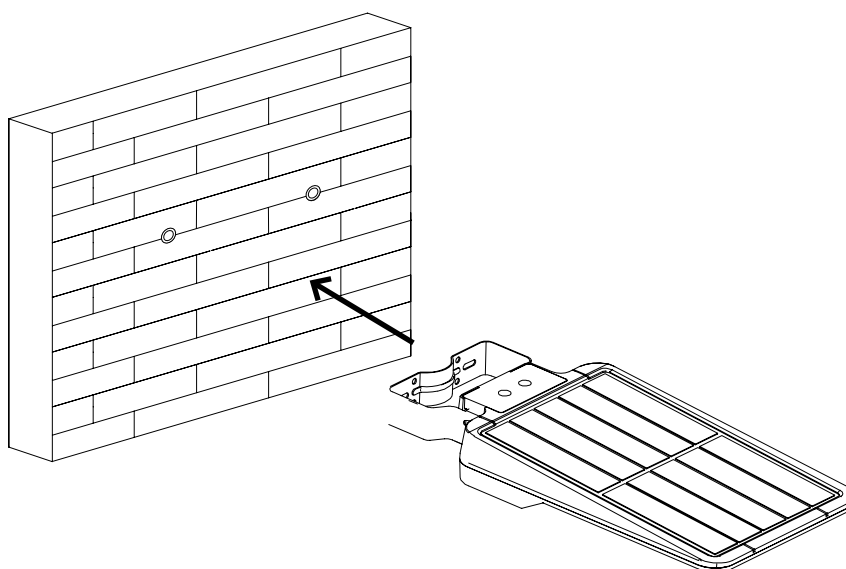

FIG.3



AVERTISSEMENT / AVISO

Hauteur d'installation 3-5m
Altura de instalação 3-5m

MONTAGE DANS POTEAU/ MONTAGEM NO PÓLO

FIG.1

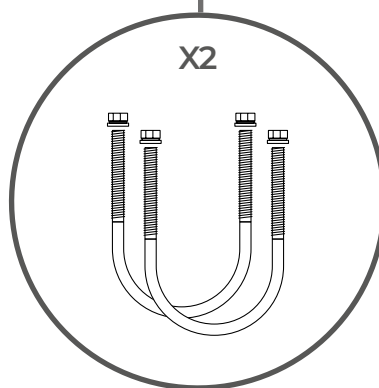
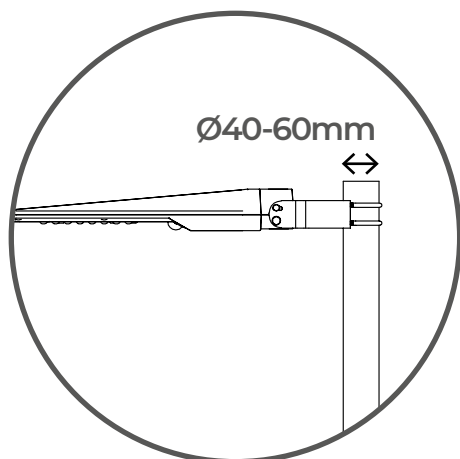
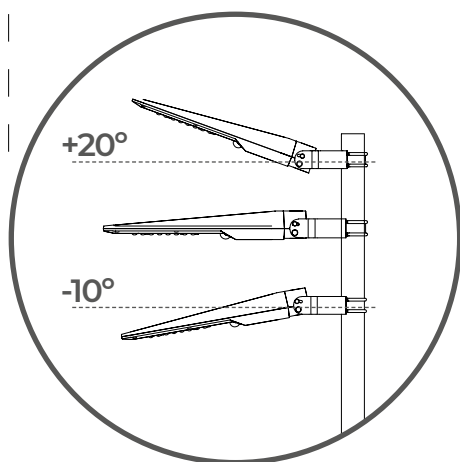
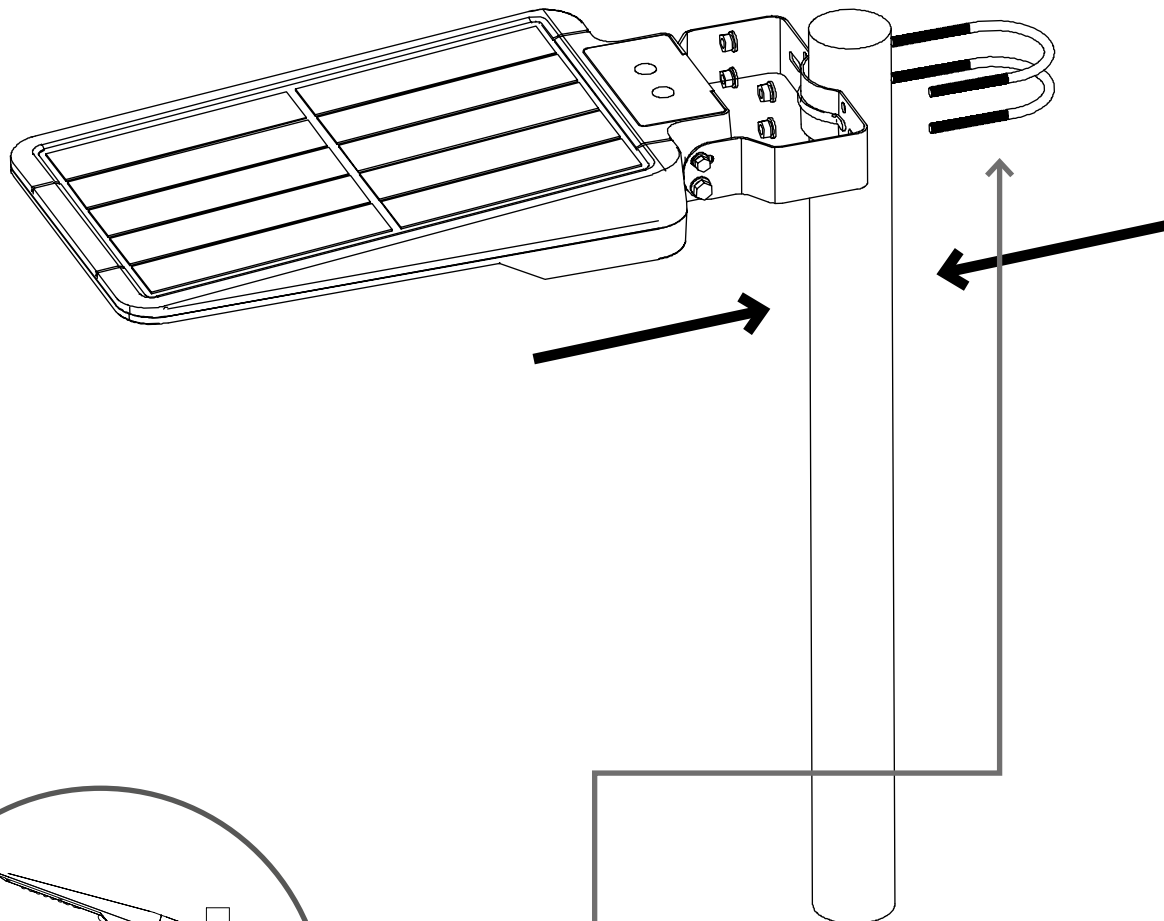

AVERTISSEMENT / AVISO

Instalación para columnas de diámetro Ø40-60mm
Colliers en U NON INCLUS
Installation for poles with diameter of Ø40-60mm
Braçadeiras em U NÃO INCLUÍDAS

MONTAGE DANS POTEAU COURBÉE/ MONTAGEM NO PÓLO CURVO

FIG.1

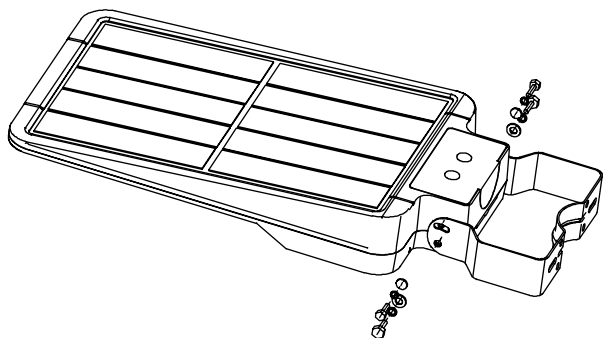

FIG.2

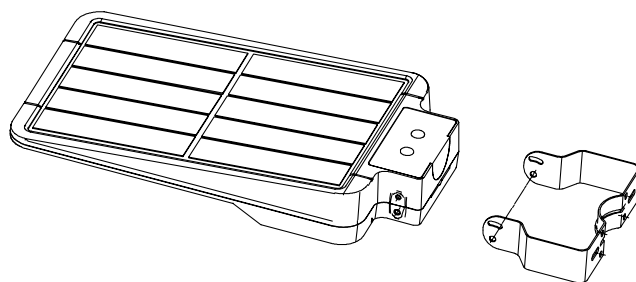

FIG.3

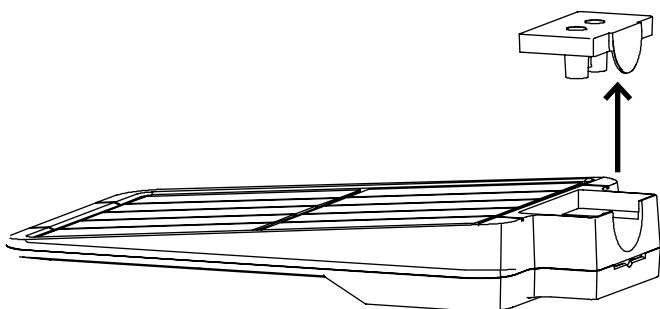

FIG.4

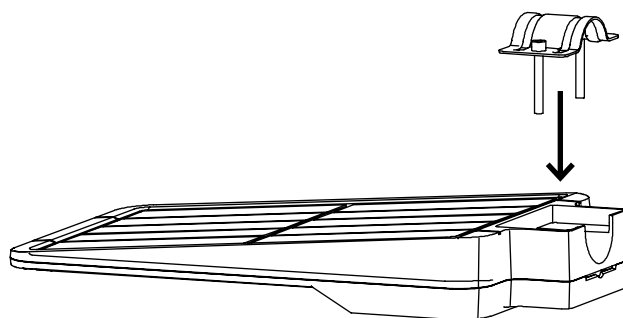
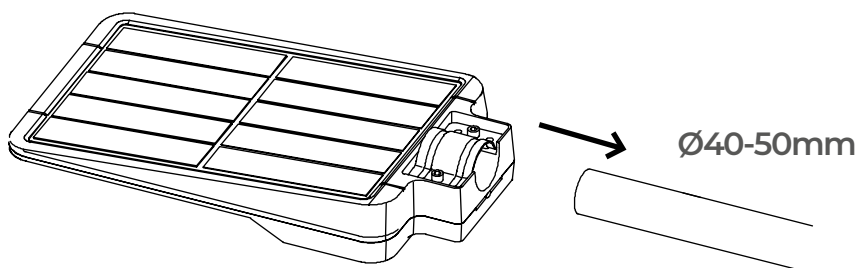

FIG.5



AVERTISSEMENT / AVISO

Installation pour poteaus diamètre de $\text{Ø}40\text{-}50\text{mm}$
Instalação para pólos de diâmetro $\text{Ø}40\text{-}50\text{mm}$

MODES D'ÉCLAIRAGE / MODOS DE ILUMINAÇÃO

Ce luminaire dispose d'un mode de fonctionnement à réglage automatique. Il vous suffit d'appuyer une fois sur le bouton, il fonctionnera en permanence.

Esta luminária tem um modo de trabalho de ajuste automático. Você só precisa pressionar o botão uma vez, ele funcionará permanentemente.

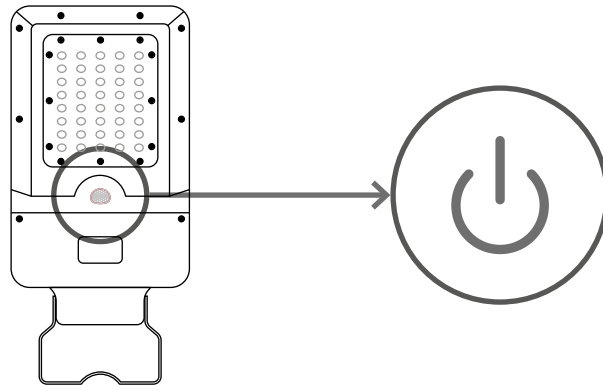

5 premières heures

Le luminaire s'allume automatiquement à son niveau maximum (100%) lorsqu'un mouvement est détecté, dans une portée allant jusqu'à 8m. Après 20 secondes sans mouvement, le niveau diminue.

Primeiras 5 horas

A luminária liga automaticamente ao seu nível máximo (100%) quando é detectado movimento, num alcance de até 8m. Após 20 segundos sem movimento, o nível diminui.

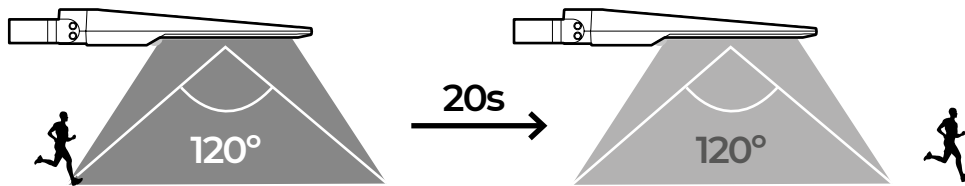

Après 5h / Niveau de batterie inférieur à 30%

Le luminaire s'allume automatiquement à son niveau maximum (100%) lorsqu'un mouvement est détecté, dans une portée allant jusqu'à 8m. Après 20 secondes sans mouvement, le niveau diminue. Après 5 minutes sans mouvement, le luminaire s'éteint.

Após 5h / Nível da bateria inferior a 30%

A luminária liga automaticamente ao seu nível máximo (100%) quando é detectado movimento, num alcance de até 8m. Após 20 segundos sem movimento, o nível diminui. Após 5 minutos sem movimento, a luminária desliga.

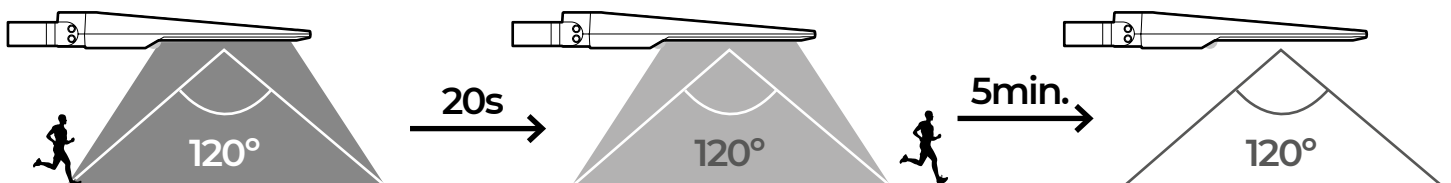

prilux.es



PRILUX

